

**VOLUMETRIC ROTARY PISTON PLASTIC BODY COLD WATER METER
MODEL: LXH-15S-20S**

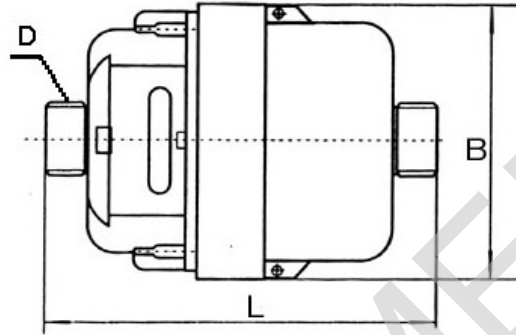

APPLICATION:

- ◆ Measuring the volume of cold potable water passing through the pipeline.

FEATURES:

- ◆ Completely plastic shell, solid and robust design, long service guaranteed.
- ◆ High quality materials fiberglass reinforced polymerization amine (UL NO.: E154352: SGS Report NO.: CE/2006/34019) corrosion resistance.
- ◆ Plastic thread connecting couplings.
- ◆ Optimum accuracy and performance at all times, in any position;
- ◆ Revolutionary grooved piston for improved, durability and performance;
- ◆ Durable tamperproof construction;
- ◆ Volumetric meter, on principle of piston rotation, accurate measurement, easy and long term clear reading, etc.
- ◆ Measuring accuracy is up to ISO4064, Class C/D

WORKING CONDITION:

- ◆ Water temperature: $\leq 50^{\circ}\text{C}$
- ◆ Water pressure: $\leq 1.6\text{MP}(16\text{bar})$

MAXIMUM PERMISSIBLE ERROR:

- ◆ In the lower zone from q_{\min} inclusive up to but excluding q_t is $\pm 5\%$
- ◆ In the upper zone from q_t inclusive up to and including q_s is $\pm 2\%$

ACCESSORIES

Optional: Both brass connections and plastic connections are available.

NINGBO AIMEI METER MANUFACTURE CO., LTD.

Address: 68 Western Town Road Shangtian Town Fenghua City Zhejiang China-315511

Tel: +86-574-88637838

Fax: +86-574-88637968

Email: aimei@chinaaimei.com

Type	Size (mm)	Class	q_s	q_p	q_t	q_{min}	Min.Reading	Max.Reading
			Max.Flow	Nominal Flow	Transitional Flow	Min. Flow		
			m ³ /h		L/h		m ³	
LXH-15S	15	C	3	1.5	22.5	15.0	0.0001	9999
		D			17.25	11.25		
LXH-20S	20	C	5	2.5	37.5	25	0.0001	9999
		D			28.75	18.75		

Type	Size	Length	Width	Connection Thread	Weight
LXH-15S	15	115	90	G3/4B	0.6kg
LXH-20S	20	190	95	G1B	0.8kg

• 流量误差曲线 Flow Error Curve

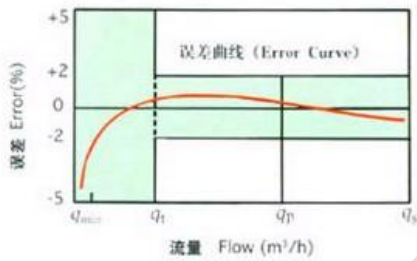

• 压力损失曲线 Head Loss Curve

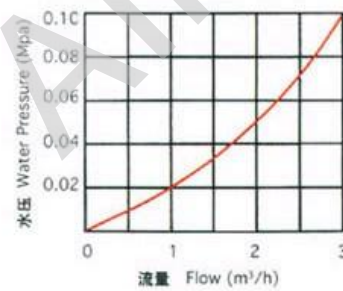

NINGBO AIMEI METER MANUFACTURE CO., LTD.

Address: 68 Western Town Road Shangtian Town Fenghua City Zhejiang China-315511

Tel: +86-574-88637838

Fax: +86-574-88637968

Email: aimei@chinaaimei.com